

KADCO USA

WWW.KADCOUSA.COM 1-800-448-5503

ASSEMBLY OF 200-TR SERIES CARTS

Assembling Handle & Legs

- A. Place the black tub body (item 1) onto a flat surface with the open side facing down. You will notice that there is a channel under the top edge (lip) of the tub.
- B. The handle (item 2) has 4 holes in it. One side has a dimpled hole. Place the handle inside the channel of the tub so that the handle protrudes from the two end openings of the tub lip. The dimpled hole side should face down & mate with the tub body. Line up the four handle holes with the four holes in the tub lip (See cart assembly diagram for position). Insert one of the $\frac{3}{4}$ " x $1\frac{1}{2}$ " slotted screws (item 7) into the second hole from the end of the tub w/handle & through corresponding handle hole. Hand tighten one of the $\frac{1}{4}$ " lock nuts (item 9) onto the screw. Repeat on other side of tub. (**DO NOT** fully tighten hardware until completing leg & handle assembly section).
- C. Tip tub on its side. Insert one of the $\frac{1}{4}$ " x $1\frac{3}{4}$ " screws (item 8) into the remaining handle hole on that side. Select one of the support legs (item 3) & note one end has a formed shape to fit over the tube shape of the handle. Place that end of the leg onto the screw & handle & hand tighten a $\frac{1}{4}$ " lock nut (item 9) onto the screw. The other end of the leg is round tube with a hole which will line up to the corresponding hole in the tub. Fit a $\frac{1}{4}$ " x $1\frac{1}{2}$ " screw (item 7) through the tub & leg (May be necessary to spring the leg slightly to ensure holes align properly). Screw another $\frac{1}{4}$ " lock nut (item 9) finger tight onto the screw.
- D. Repeat step C to install second leg.
- E. You will notice a hole in the side of the legs for the cross brace (item 4). Fit the cross brace between the rear struts of the legs as shown in the diagram with the tube portion against the bottom of the cart tub. Fit two screws $\frac{1}{4}$ " x $1\frac{1}{2}$ " (item 7) from the outside through the holes in the legs & cross brace. Install two $\frac{1}{4}$ " lock nuts (item 9). The screw head should be on the outside. (Notice one side of the hole in the leg is dimpled where the screw is positioned while the other side is not. This is standard as all the legs are punched the same so the legs will fit either side.)
- F. You've now installed all handle & leg parts of the cart! Proceed to tighten all nuts with a $7/16$ " socket or wrench. The screw head should be held from turning with a large flathead screwdriver.

Assembly of Axle, Axle Supports & Wheels

- A. Place tub body on its side. Reaching into tub body, place one stainless washer plate (item 16) over the two holes at the bottom of the tub body, place two carriage bolts (item 10) through the holes so they protrude out of the bottom of the tub body.
- B. Place axle assembly over the carriage bolts so the axle plate holes align with the bolts.
- C. Place two 3/8" washers (item 14) over the bolts which are protruding from the bottom of the axle assembly.
- D. Put two 5/16" lock nuts (item 11) onto the bolts and hand tighten.
- E. Flip the tub onto the opposite side & repeat steps A-C. **DO NOT TIGHTEN AXLE NUTS YET.**
- F. To install axle supports (item 5) flip the tub upside down. Place the notched end onto the axle rod with the small right-angled portion facing out. The notched end should be positioned between the inside of welded washer on the axle & tub body. *This keeps the support from interfering with the wheel when installed. Note: for easier assembly the supports can be installed in an angled position coinciding with the rounded underside of the tub lip.* Using a large flat screwdriver, scoot that end of the support into the perpendicular position & the oval hole in the support lines up with the corresponding hole in the tub. Now install one ¼" x 1" screw (item 12) into the hole in tub & through the support. Thread one ¼" locknut (item 9) on the underside. When both supports are installed, you may tighten these screws using flat screwdriver. & 7/16" wrench. *Note: Only tighten the nut to where the support is fitting snugly into the rounded channel of the tub lip. Over tightening with result in distortion of tub lip.* The support is a tight fit between the axle & tub lip. It will not dislodge from the axle when using your cart.
- G. At this point the nuts holding the axle should be tightened. Tighten the carriage bolts, be careful not to overtighten the nuts.
- H. Installing wheels. Place one wheel (item 15) onto axle end & slide into position so center bearing fits against welded washer. Select a wheel locknut (item 13) & thread onto the axle hand tight. You should only get a couple turns before lock section binds on the thread. Using 10 or 12" adjustable wrench, carefully begin to tighten the wheel nut while turning the wheel. As nut begins to tighten, you'll notice the wheel turning more firmly. Tighten the nut until you feel the resistance is such that the wheel no longer turns freely. Loosen the nut an 1/8th of a turn & spin the wheel. If wheel spins freely, you have the correct tightness. If there's still resistance loosen another 1/8th. Repeat procedure for other wheel.
- I. Now you've assembled your cart and should enjoy years of trouble free service. For all replacements parts you can shop online at WWW.KADCOUSA.COM or call **518-705-4321** or toll free at **1-800-448-5503**

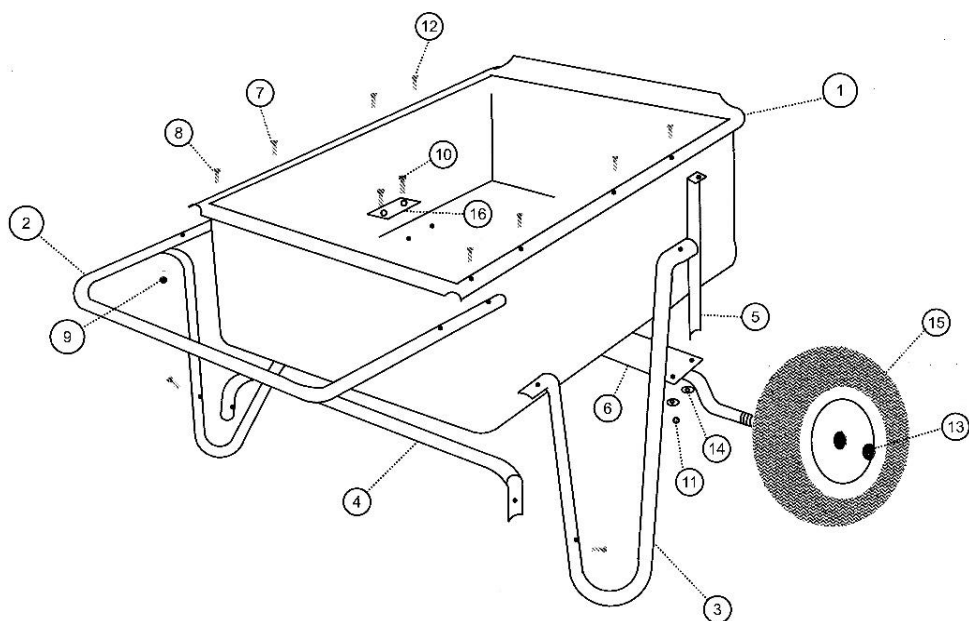

Contents	Part Number	Qty
1. Tub Body	200-010	1
2. Handle	200-030	1
3. Support Leg	200-040	2
4. Cross Brace	200-051	1
5. Axle Support	200-052-1	2
6. Axle Assembly $\frac{3}{4}$	200-020-1	1
7. $\frac{1}{4}$ " x $1\frac{1}{2}$ " Slotted Screw	200-908	6
8. $\frac{1}{4}$ " x $1\frac{3}{4}$ " Slotted Screw	200-903	2
9. $\frac{1}{4}$ " Nyloc Nut	200-904	10
10. $\frac{5}{16}$ " x 1" Stainless Carriage Bolt	200-901-1	4
11. $\frac{5}{16}$ " SS Nyloc Nut	200-907	4
12. $\frac{1}{4}$ " x 1" Slotted Screw	200-906	2
13. $\frac{3}{4}$ " -11 Lock Nut	200-902-1	2
14. $\frac{3}{8}$ " Flat Washer	200-905	4
15. Wheel Assembly TR	200-074	2
16. Stainless Washer Plate	200-022-2	2

Thank you for choosing the Kadco Carry-It Cart. We have been manufacturing these carts for over 30 years in the USA. You can rest easy knowing that you purchased a quality product that will provide years of good use. Many of our carts are still in use after more than 25 years of service. We invest a lot of time selecting the materials we use to manufacture our products. The tubing on your cart is made from Allied Zinc Flo-Coat® steel. This zinc coating process provides uniform corrosion resistant finish and a protective clear coating. Our cart bodies are made from black recycled HMPE plastic that will endure the sun's harsh UV rays. We vigorously test our carts in a variety of situations to be sure that they exceed our specifications and, more importantly, your expectations. Please contact us with any comments or concerns.

KADCO USA

PO Box 584
Amsterdam, NY 12010
800-448-5503
www.kadcousa.com



These simple tools are required:

- Screwdriver
- 7/16" deep socket or wrench
- 1/2" deep socket or wrench
- 10" adjustable wrench



Made in the USA

© 2003 Kadco USA Inc. All rights reserved.